

**GENERAL NOTES
(UNLESS OTHERWISE SPECIFIED)**

1. Fabricate per AC 43.13.
2. Assembly shop practice per AC 43.13.
3. Flange corner radii are to be R .25.
4. Alodine all aluminum parts per Mil-C-5541.
5. Epoxy prime per Mil-P-23377.
6. Remove all burrs and sharp edges.
7. Torque per AC 43.13-1A or MIL-N-25027.
8. Surface finish of parts to be 125 microinches
9. Install safety wire per AC 43.13-1A or MS33540.
10. All dimensions are prior to finish applications.
11. Equally spaced attachment tolerance to be +/- 0.100".
12. Minimum attachment spacing to be 4D+.060" center to center.
13. Attachments located from part edge 2D+.060" for details, 2D minimum on assembly, 2D from joggles and adjacent structure.
14. Identify per MIL-STD-130 using rubber stamp or and written with indelible ink. Small assemblies may be tagged.
15. Symbols + between end fastener symbols indicate identical fasteners equally spaced.
16. Install solid rivets per AC 43.13-1A. Install all other fasteners per manufacturer's instructions.
17. Faying surface seal all external skin mating joints and install fasteners wet using PR1431G or P/S 870C sealant.
18. Fillet or brush coat edges of mating parts using PR1422-B2, CS3204 class B, or P/S 890 class B sealant.
19. Mix all sealants and adhesives per the Mfg's instructions.
20. Antenna must be bonded to airframe for P-static and lightning protection. Reference AC 43.13-1B Chapter 12 Section 2 Paragraph 12-9 (b) for inspection antenna guideline & Chapter 11 Section 15 Paragraph 11-193 for lightning protection. Also reference a/c manufacturer's maintenance manual for recommended antenna bonding practices.
21. Install thru doubler only.

INSTALLATION NOTES

- A. Install the S67-1575-165 Antenna at FS xxx BL 0.0 per the manufacturer's instructions.
- B. Doubler may be larger, and fastener spacing greater than shown. Flanges may be added. Nuts and washers may be used in place of nutplates.

This drawing has been prepared for a specific alteration to a specific aircraft or component based on information supplied to Aviation Engineering Consultants of USA, LLC (AECUSA-LLC) by the person responsible for arranging the alteration or his agent. The use of the data on any other aircraft or component may lead to an unsafe alteration and therefore the data is not to be used for any other purpose than for which it was originally supplied without the written approval of AECUSA-LLC.

REVISIONS				
ZONE	REV	DESCRIPTION	DATE	APPROVED
	-	Initial Release	2011-0X	J.BROWN

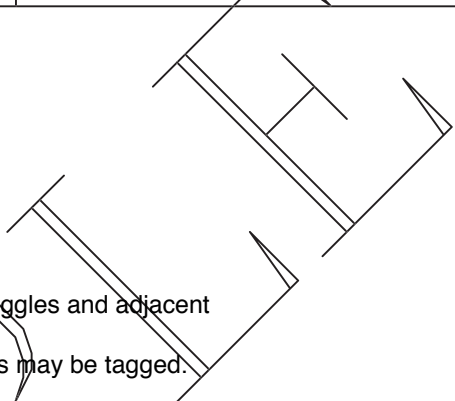

NAS 523 FASTENER CODE	
BASIC CODE	DASH NO. FOR DIA. N = MFD HEAD NEAR SIDE F = MFD HEAD FAR SIDE
D = DIMPLE FIGURE = NO. OF SHEETS TO BE DIMPLED C = COUNTERSUNK	DASH NO. FOR LENGTH W = SPOTWELD OPTIONAL
BASIC CODES	
BB = MS20426AD	LZ = NAS1097AD
BJ = MS20470AD	
YA = HL18PB70	

QTY	NOTE	PART NO.	NOMENCLATURE OR DESCRIPTION	MATERIAL/SPECIFICATION	STOCK SIZE	ITEM NO.
4		10-32UNC-2A	Screw			7
1		S67-1575-165	Antenna	Sensor Systems, Inc.		6
1		-03	Doubler Assy			5
8	21	MS20426AD3	Rivet			4
4	B	MS21062-3	Nutplate			3
1	4, 5	-02	Doubler	0.040 2024-T3, AMS-QQ-A-250/5	0.040 x 5 x 4	2
	1	-01	Installation			1

PARTS LIST

DIMENSIONS ARE IN INCHES
TOLERANCES:
.XX = ±.03
.XXX = ±.015
ANGLES ±0°-30'

NOTICE - This drawing is the property of Aviation Engineering Consultants of USA, LLC, and any disclosure of its contents to others is given in confidence. It must not be reproduced or copied in whole or in part or used in any way except with specific approval and permission of the General Manager of Aviation Engineering Consultants of USA, LLC



TITLE: S67-1575-165 IRIDIUM GPS ANTENNA INST - XX
APPRVD *J. BROWN* 2011-0X DWG. NO. 00-1500-03-19-xxx SHEET 1 OF 3

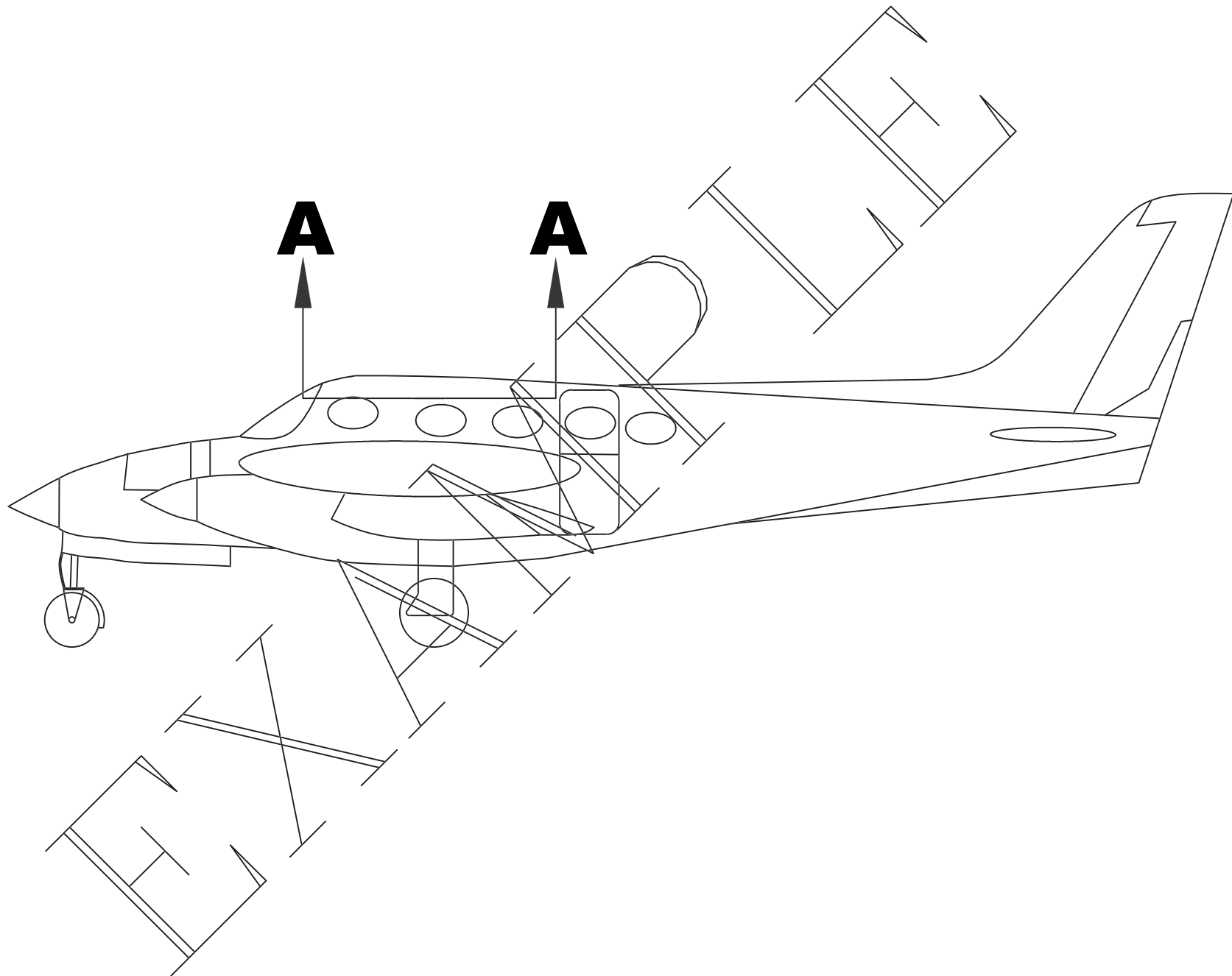

-01 ANTENNA INSTALLATION

DIMENSIONS ARE IN INCHES
 TOLERANCES:
 .X = ±.1, .XX = ±.03
 .XXX = ±.015
 ANGLES ±0°-30'

NOTICE - This drawing is the property of Aviation Engineering Consultants of USA, Inc., and any disclosure of its contents to others is given in confidence. It must not be reproduced or copied in whole or in part or used in any way except with specific approval and permission of the General Manager of Aviation Engineering Consultants of USA, Inc.



AVIATION ENGINEERING
 CONSULTANTS of USA, LLC
 Cape Coral, FL
 800-977-1992

TITLE: S67-1575-165 IRIDIUM GPS ANTENNA INST - XX

DWG. NO. 00-1500-03-19-XXX

Rev. - SHEET 2

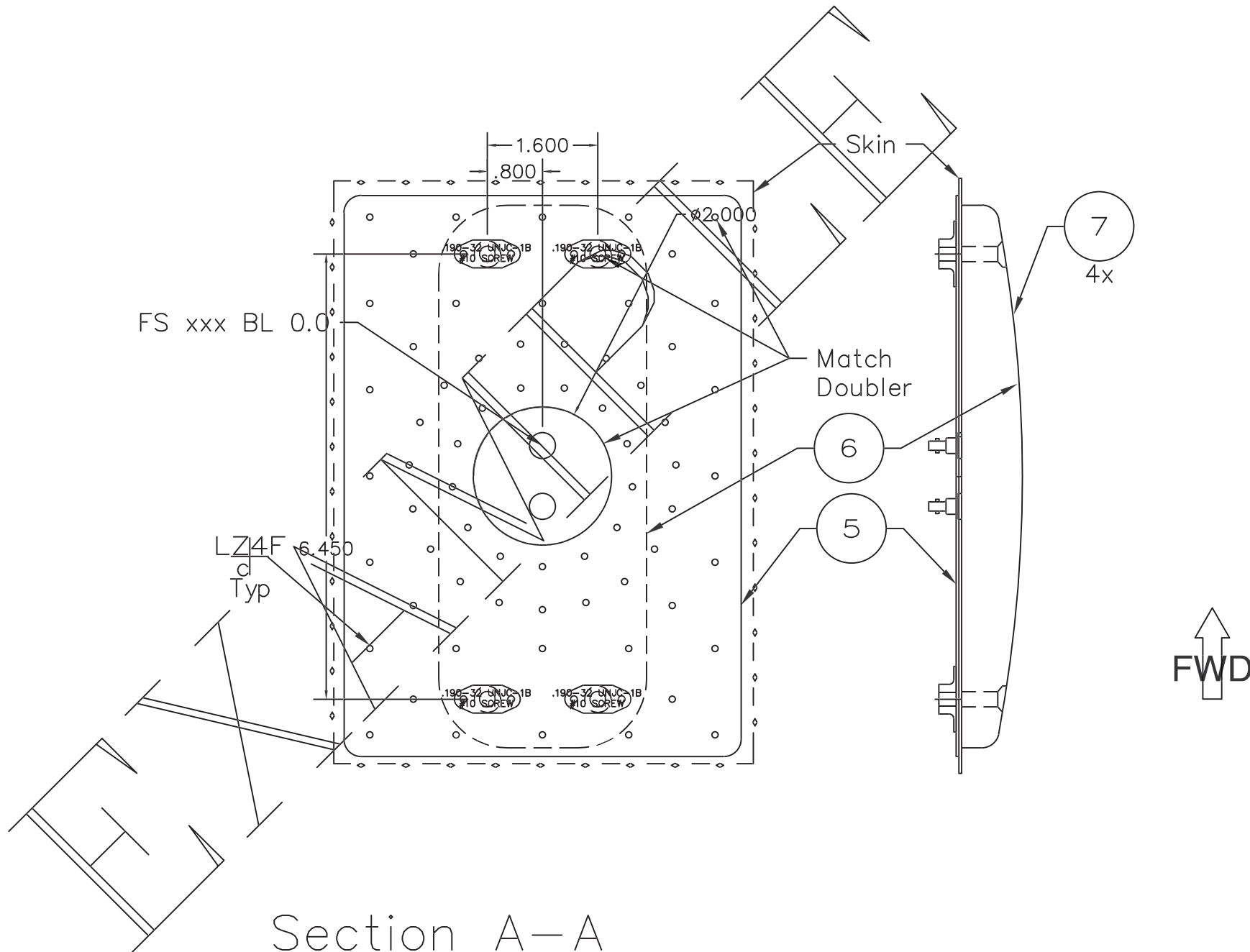

Section A-A
Rotated 90° CW

DIMENSIONS ARE IN INCHES
TOLERANCES:
.X = ±.1, .XX = ±.03
.XXX = ±.015
ANGLES ±0°-30'

NOTICE - This drawing is the property of Aviation Engineering Consultants of USA, Inc., and any disclosure of its contents to others is given in confidence. It must not be reproduced or copied in whole or in part or used in any way except with specific approval and permission of the General Manager of Aviation Engineering Consultants of USA, Inc.

στ AVIATION ENGINEERING
CONSULTANTS of USA, LLC
Cape Coral, FL
800-977-1992

TITLE: S67-1575-165 IRIDIUM GPS ANTENNA INST - XX
DWG. NO. 00-1500-03-19-XXX
Rev. - SHEET 3

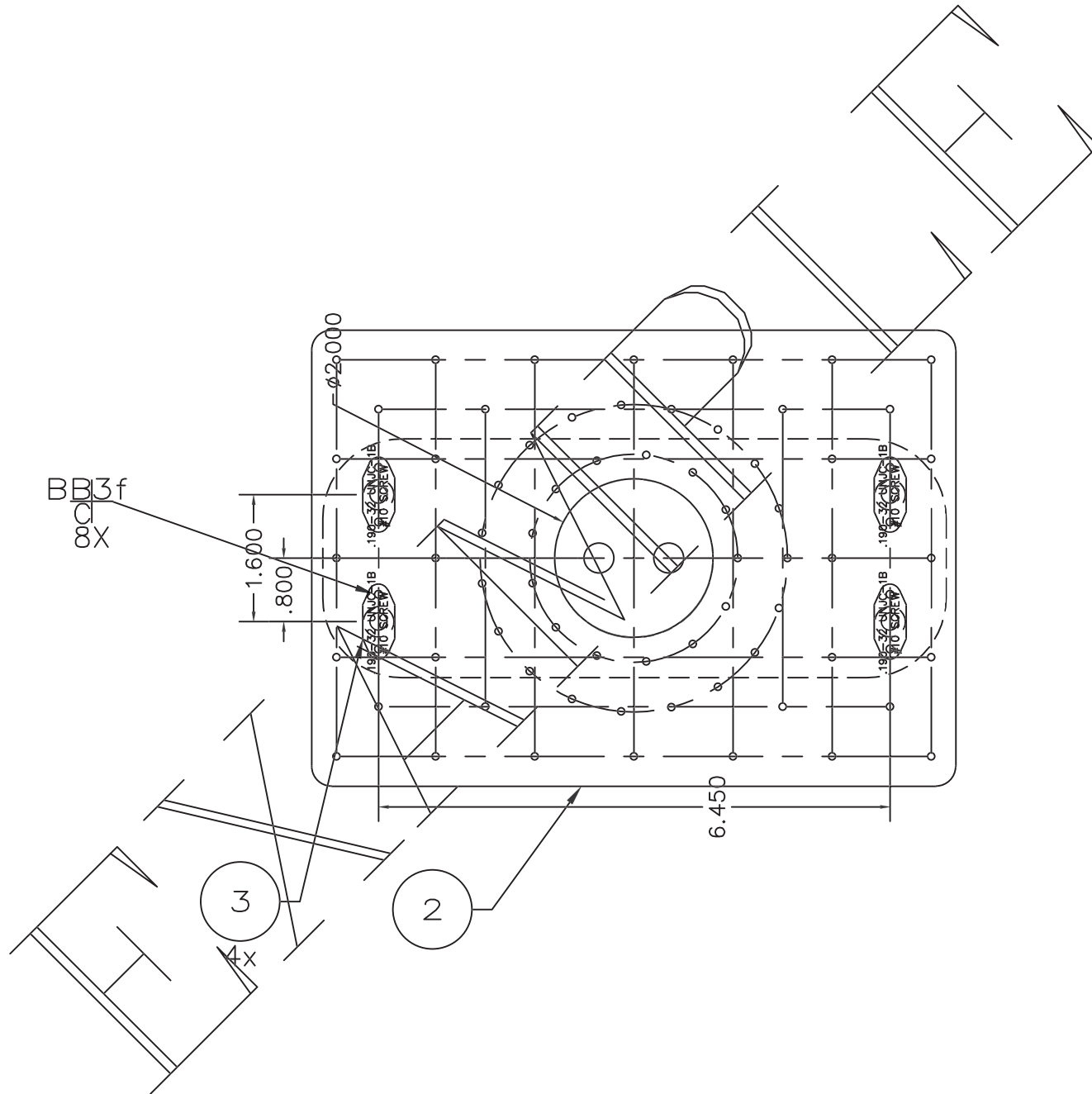

-03 DOUBLER ASSY

DIMENSIONS ARE IN INCHES
 TOLERANCES:
 .X = ±.1, .XX = ±.03
 .XXX = ±.015
 ANGLES ±0°-30'

NOTICE - This drawing is the property of Aviation Engineering Consultants of USA, Inc., and any disclosure of its contents to others is given in confidence. It must not be reproduced or copied in whole or in part or used in any way except with specific approval and permission of the General Manager of Aviation Engineering Consultants of USA, Inc.



AVIATION ENGINEERING
 CONSULTANTS of USA, LLC
 Cape Coral, FL
 800-977-1992

TITLE: S67-1575-165 IRIDIUM GPS ANTENNA INST - XX

DWG. NO. 00-1500-03-19-XXX

Rev. - SHEET 4